



Mobilier de la Villa Church, Ville d'Avray, 1928 © Le Corbusier, Pierre Jeanneret, Charlotte Perriand /ADAGP. Source FLC/ACHP

ITA

Con i diversi modelli di Fauteuil Grand Confort, grand modèle la logica della modernità attua una separazione tra la struttura portante in metallo e gli elementi imbottiti. I cuscini, privi di legami, sono disposti in una gabbia di tubi di acciaio verniciato o cromato che costituisce il supporto primario del mobile in ogni sua declinazione, dalla poltrona con bracciolo singolo o doppio ai divani a due o tre posti. Nel corso degli anni Cassina ha collaborato a stretto contatto con Charlotte Perriand, la figlia Pernette e la Fondation Le Corbusier per introdurre nuove versioni e finiture che pur reinterpretando il progetto originale ne rispettano pienamente l'autenticità.

Questi modelli sono disponibili anche in una versione più ecologica. Grazie allo studio eseguito da Cassina LAB, una collaborazione tra il Centro di Ricerche e Sviluppo di Cassina e Poli. design del Politecnico di Milano, gli elementi schiumati, l'imbottitura dei cuscini e la struttura tubolare sono realizzati con materiali e processi più sostenibili.

DEU

Bei den verschiedenen Modellen des Sessels Fauteuil Grand Confort, grand modèle wird die Logik der Moderne mit der Trennung von tragendem Gestell aus Metall und gepolsterten Elementen umgesetzt. Die Kissen sind ohne Befestigung in einem Rahmen aus lackierten oder verchromten Stahlprofilen angeordnet, der das Hauptgestell dieses ikonischen Sessels in allen seinen Ausführungen bildet, vom Sessel mit einer oder zwei Armlehnen bis zu den Zweisitzer- oder Dreisitzersofas. Im Laufe der Jahre hat Cassina eng mit Charlotte Perriand, ihrer Tochter Pernette und der Fondation Le Corbusier zusammengearbeitet, um neue Versionen und Oberflächen einzuführen, die zwar eine Neuinterpretation des Originalentwurfs darstellen, dessen Authentizität aber in jeder Hinsicht respektieren. Diese Modelle sind auch in einer umweltfreundlicheren Version erhältlich. Die Studien, die Cassina LAB, das Forschungs- und Entwicklungszentrum von Cassina, in Zusammenarbeit mit dem Kompetenzzentrum für Design Poli.Design des Polytechnikums Mailand durchgeführt hat, haben die Herstellung der geschäumten Elemente, der Kissenpolsterung und des Gestells aus Hohlprofil mit nachhaltigeren Materialien und Prozessen ermöglicht.

ENG

With the various models of Fauteuil Grand Confort, grand modèle, the concept of modernity is expressed through the separation between the metal support frame and the upholstered elements. The loose cushions are set inside a painted or chrome-plated tubular steel cage that forms the primary support for the piece in all its variations – from the armchair with armrest on one or both sides, to the two- and three-seat sofas. Over the years, Cassina has worked very closely with Charlotte Perriand, her daughter Pernette and the Fondation Le Corbusier to introduce new versions and finishes that, while reinterpreting the original design, remain faithful to its authentic nature. These models are also available in an eco-friendly version. Thanks to a study conducted by Cassina LAB, a partnership between the Cassina Research and Development Center and the Poli.design consortium of the Politecnico University in Milan, the foam-fill parts, the padding in the cushions and the tubular structure are produced with sustainable materials and processes.

FRA

Avec les différents modèles du Fauteuil Grand Confort, grand modèle, la volonté de modernité inspire la séparation entre la structure porteuse en métal et les éléments rembourrés. Pour ces modèles, des coussins dissociés sont disposés dans une structure de tubes d'acier peint ou chromé. Elle constitue le support principal du meuble dans toutes ses déclinaisons, du fauteuil à accoudoir simple ou double aux canapés à deux ou trois places. Au fil des ans, Cassina a travaillé en étroite collaboration avec Charlotte Perriand, sa fille Pernette et la Fondation Le Corbusier, pour proposer de nouvelles versions et finitions qui, tout en adaptant le projet original, respectent son authenticité. Ces modèles sont aussi disponibles dans une version écologique. Grâce à l'étude effectuée par Cassina LAB, une collaboration entre le Centre de recherche et de développement de Cassina et le Poli.design du Politecnico di Milano les éléments en mousse, le rembourrage des coussins et la structure tubulaire sont réalisés avec des matériaux et un processus de production plus écologiques.



LC
PJ
CP

Cassina iMaestri Collection

Collection Le Corbusier®, Pierre Jeanneret®, Charlotte Perriand®

Designed by

Le Corbusier, Pierre Jeanneret,
Charlotte Perriand, 1928

Produced

Cassina, 1965



a



b



Cassina iMaestri Collection
Collection Le Corbusier®, Pierre Jeanneret®,
Charlotte Perriand®

Designed by

Le Corbusier, Pierre Jeanneret,
Charlotte Perriand, 1928

Produced

Cassina, 1978

Adaptation de Charlotte Perriand
pour Cassina en 1978



Cassina iMaestri Collection
Collection Le Corbusier®, Pierre Jeanneret®,
Charlotte Perriand®

Designed by

Le Corbusier, Pierre Jeanneret,
Charlotte Perriand, 1928

Produced

Cassina, 2006





Cassina iMaestri Collection
Collection Le Corbusier®, Pierre Jeanneret®,
Charlotte Perriand®

Designed by
Le Corbusier, Pierre Jeanneret,
Charlotte Perriand, 1928

Produced
Cassina, 2006



Cassina iMaestri Collection
Collection Le Corbusier®, Pierre Jeanneret®,
Charlotte Perriand®

Designed by
Le Corbusier, Pierre Jeanneret,
Charlotte Perriand, 1928

Produced
Cassina, 2020





Cassina iMaestri Collection

Collection Le Corbusier®, Pierre Jeanneret®, Charlotte Perriand®

Designed by

Le Corbusier, Pierre Jeanneret,
Charlotte Perriand, 1928

Produced

Cassina, 2020

Adaptation de Charlotte Perriand
pour Cassina en 1978



Cassina iMaestri Collection

Collection Le Corbusier®, Pierre Jeanneret®, Charlotte Perriand®

Designed by

Le Corbusier, Pierre Jeanneret,
Charlotte Perriand, 1928

Produced

Cassina, 2020





Cassina iMaestri Collection
Collection Le Corbusier®, Pierre Jeanneret®,
Charlotte Perriand®

Designed by
Le Corbusier, Pierre Jeanneret,
Charlotte Perriand, 1928

Produced
Cassina, 2020

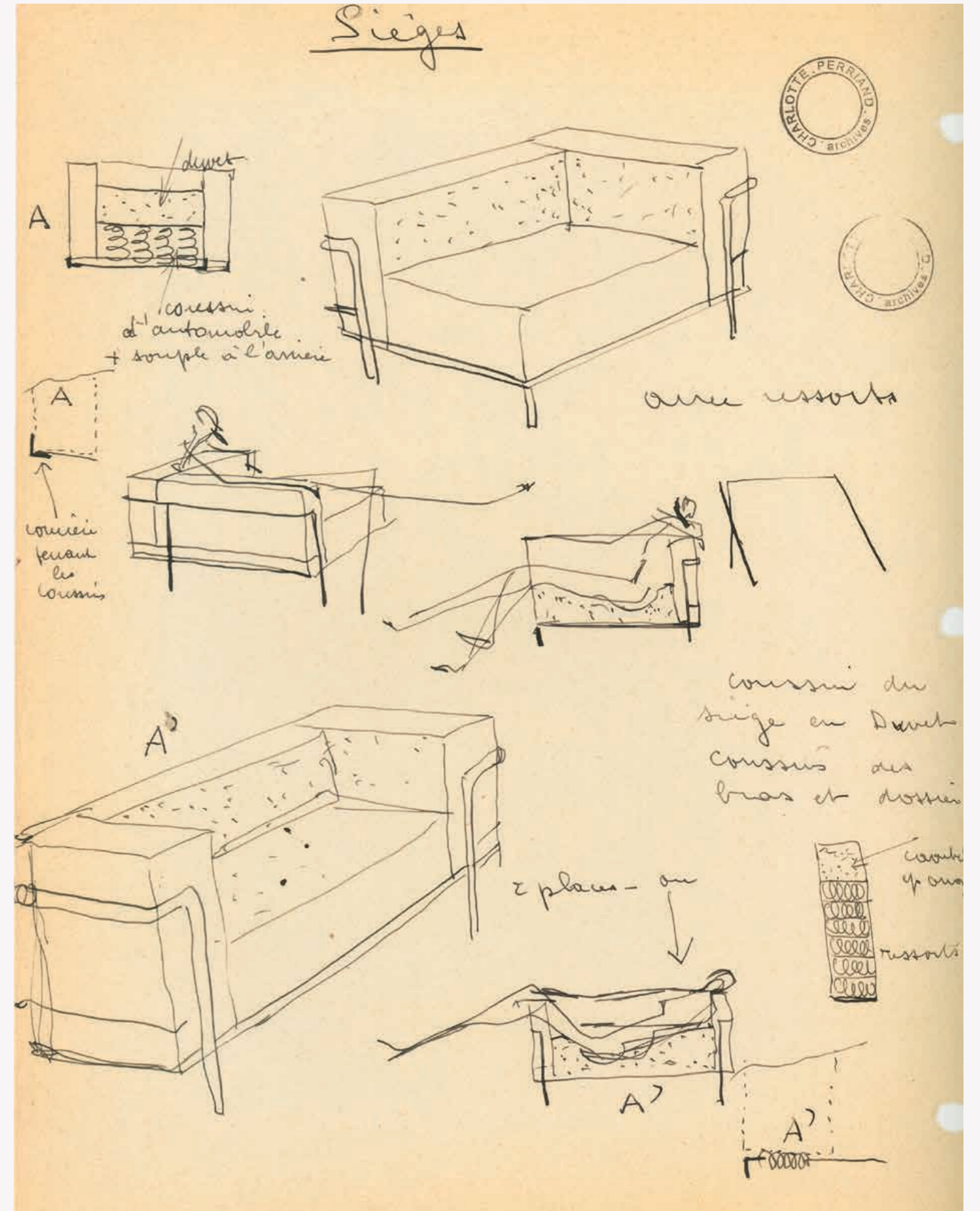

Étude de déclinaison du fauteuil Grand confort de Le Corbusier, Pierre Jeanneret, Charlotte Perriand. Croquis de Charlotte Perriand © Archives Charlotte Perriand /ADAGP. Source AChP

Struttura

- Telaio in tubolare d'acciaio. Finitura cromata lucido o verniciato nei colori indicati a listino.
- Imbottitura cuscini
- Poliuretano schiumato con inserto in poliuretano espanso.
- Ovatta in fibra di poliestere resinata accoppiata con tela o piumino d'oca nella versione in piuma.
- Rivestimento
- Tessuto o pelle.
- Telaio seduta
- In acciaio profilato angolare, cromato o verniciato nei colori elencati a listino e dotato di cinghiatura elastica.
- Piedino
- In materiale plastico con finitura nera.

VERSIONE DURABLE

Struttura

- Telaio in tubolare d'acciaio. Finitura cromata lucido, nickel spazzolato o verniciato nei colori indicati a listino.
- Imbottitura cuscini
- Poliuretano flessibile con polioli ecocompatibili derivanti da fonti bio rinnovabili con inserto in poliuretano espanso.
- Fibra di PET riciclata al 100%, accoppiata con vellutino. Rivestimento
- Tessuto o pelle.
- Telaio seduta
- In acciaio profilato angolare, cromato, nickel spazzolato o verniciato nei colori elencati a listino e dotato di cinghiatura elastica.
- Piedino
- In materiale plastico con finitura nera.

Finiture/Finishes/ Ausführungen/Finitions



a

Lipari 13L631 — Verniciato marrone/
Brown enamel/Braun lackiert/Verni
marron



b

Pelle/Leather/Leder/Cuir Extra 13Y253
— Verniciato grigio/Grey enamel/Grau
lackiert/Verni gris

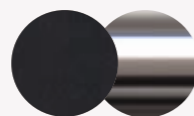

c

Pelle/Leather/Leder/Cuir LCX 13Y414
— Cromato/Chrome plated/Verchromt/
Chromé

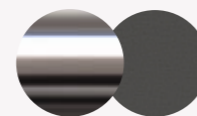

d

Cromato/Chrome plated/Verchromt/
Chromé — Pelle/Leather/Leder/Cuir
13Z304



e

Verniciato marrone/Brown enamel/
Braun lackiert/Verni marron —
Francoforte 13F093



f

Pelle/Leather/Leder/Cuir LCX 13Y414
— Nickel spazzolato/Brushed nickel/
Nickelgrau Gebürstet/Nickel brossé



g

Verniciato grigio/Grey enamel/Grau
lackiert/Verni gris — Pelle/Leather/
Leder/Cuir LCX 13Y412

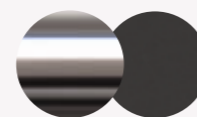

h

Cromato/Chrome plated/Verchromt/
Chromé — Francoforte Fumo 13F106



i

Verniciato marrone/Brown enamel/
Braun lackiert/Verni marron — Pelle/
Leather/Leder/Cuir 13Y246



l/m

Pelle/Leather/Leder/Cuir LCX 13Y414
— Cromato/Chrome plated/Verchromt/
Chromé

Structure

- Frame in tubular steel. Polished chrome, or painted finish in the colours shown on the price list.
- Cushion padding
- Polyurethane foam fill with polyurethane foam insert.
- Resin-treated polyester fibre batting laminated to fabric, or goose down in the feather version.
- Upholstery
- Fabric or leather.
- Seat frame
- In steel angle bar with elastic webbing, chrome-plated or painted in the colours shown on the price list.
- Feet
- In plastic with black finish.

DURABLE VERSION

Structure

- Frame in tubular steel. Polished chrome or brushed-nickel finish, or painted in the colours shown on the price list.
- Cushion padding
- Flexible polyurethane foam with eco-friendly polyols derived from renewable bio-based resources, with polyurethane foam insert.
- 100% recycled PET fibre, laminated to fabric lining.
- Upholstery
- Fabric or leather.
- Seat frame
- In steel angle bar with elastic webbing, chrome-plated or brushed-nickel finish, or painted in the colours shown on the price list.
- Feet
- In plastic with black finish.

Gestell

- Rahmen aus Hohlprofil aus Stahl. Oberfläche verchromt glänzend oder lackiert in den Farben nach Preisliste.
- Polsterung Kissen
- PU-Schaum mit Einsatz aus PU-Hartschaum.
- Polsterwatte aus Polyesterharzfasern mit Stoffhülle oder mit Gänsedaunen in der Version mit Daunenfüllung.
- Bezug
- Stoff oder Leder.
- Rahmen Sitzfläche
- Aus Winkelprofil aus Stahl, verchromt oder in den Farben nach Preisliste, mit elastischen Riemen.
- Gleiter
- Aus Kunststoff mit schwarzer Oberfläche.

VERSION DURABLE

Gestell

- Rahmen aus Hohlprofil aus Stahl. Oberfläche verchromt glänzend, vernickelt gebürstet oder lackiert in den Farben nach Preisliste.
- Polsterung Kissen
- PU-Weichschaum mit umweltfreundlichen Polyolen aus erneuerbaren Bio-Quellen, mit Einsatz aus PU-Hartschaum.
- Fasern aus 100% recyceltem PET mit Vlies. Bezug
- Stoff oder Leder.
- Rahmen Sitzfläche
- Aus Winkelprofil aus Stahl, verchromt, vernickelt gebürstet oder mit Lackierung in den Farben nach Preisliste, mit elastischen Riemen.
- Gleiter
- Aus Kunststoff mit schwarzer Oberfläche.

Structure

- Cadre en acier tubulaire. Finition chromé brillant ou peint dans les couleurs disponibles dans la liste des produits.
- Rembourrage des coussins
- Polyuréthane injecté avec insert en mousse polyuréthane.
- Multicouche en ouate de fibre de polyester résinée et toile ou duvet d'oie dans la version en plume.
- Revêtement
- Tissu ou cuir.
- Cadre de l'assise
- En acier profilé angulaire, chromé ou peint dans les couleurs disponibles dans la liste de produits et équipé de sangles élastiques.
- Embouts de pieds
- En matériau plastique, finition noir.

VERSION DURABLE

Structure

- Cadre en acier tubulaire. Finition chromé brillant, nickel brossé ou peint dans les couleurs disponibles dans la liste des produits.
- Rembourrage des coussins
- Polyuréthane flexible avec des polyols écocompatibles issus de sources bio renouvelables avec insert en mousse polyuréthane.
- Multicouche en fibre de PET 100% recyclé et tissu.
- Revêtement
- Tissu ou cuir.
- Cadre de l'assise
- En acier profilé angulaire, chromé, nickel brossé ou peint dans les couleurs disponibles dans la liste de produits et équipé de sangles élastiques.
- Embouts de pieds
- En matériau plastique, finition noir.

003 1/E_

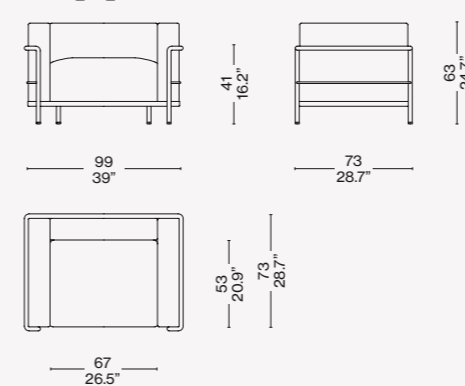

003 2/F_

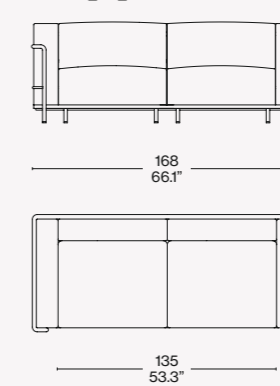

003 A/G_

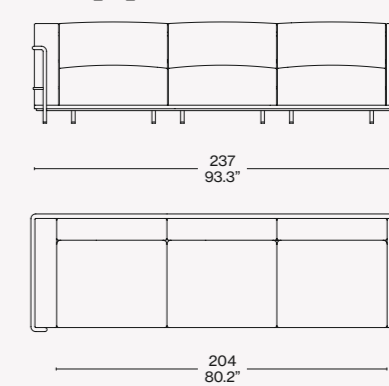

003 B/H_

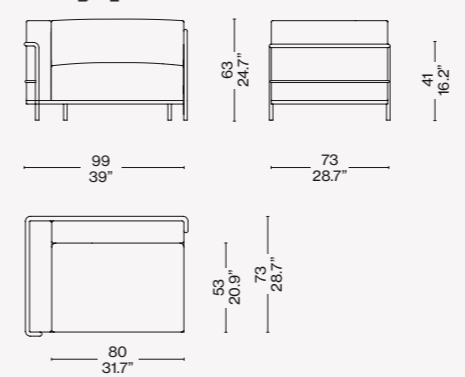

003 C/L_

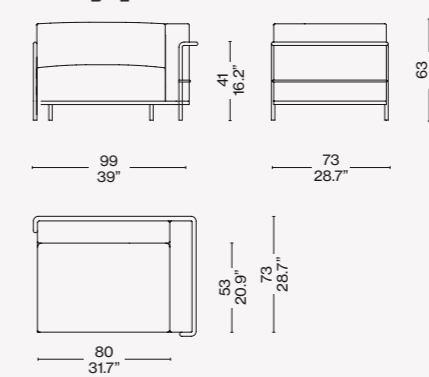

Identifying marks and production numbers

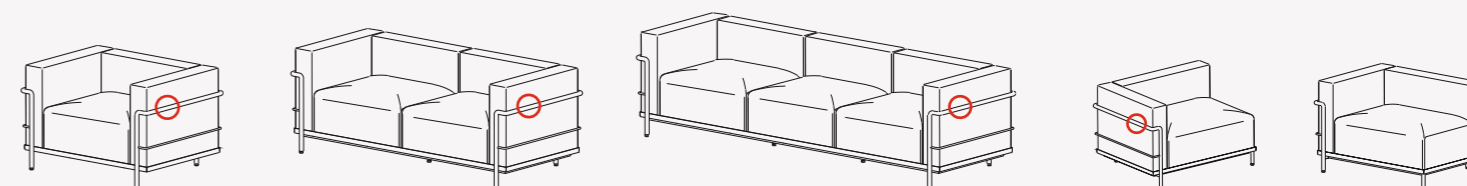

Cassina  LC
PJ
CP N°..... *Le Corbusier® Pierre Jeanneret® Charlotte Perriand®*